

REVISIONS					
REV	DATE	ECN #	DESCRIPTION	BY	APPD
1	8/19/2014	HJ14-165	REMOVED UNNECESSARY GASKET	CLS	BLB
2	5/21/2015	HJ15-104	ADDED NOTE 3	CLS	BLB

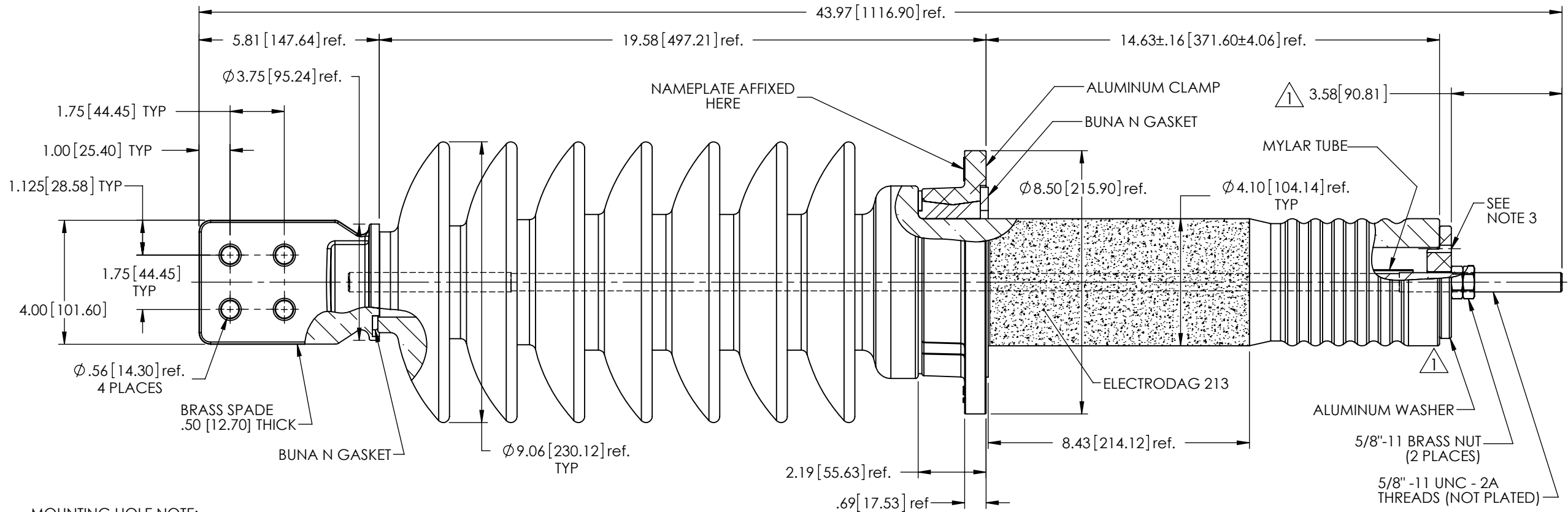

MOUNTING HOLE NOTE:

1. LOCATED ON A Ø7.25[184.15] ON THE ALUMINUM CLAMP.
2. FOUR(4) THRU HOLES AT Ø.688[17.46] EQUALLY SPACED 90° APART.

MATERIAL:

STUD - COPPER C11000
 SPADE - C84400 TIN PLATED

NOTES:

1. SHANK TO FIT INTO Ø4-1/2" TANK HOLE.
2. FOR HORIZONTAL MOUNTING.
3. ALUMINUM WASHER TO BE ORIENTED SUCH THAT TWO OIL ENTRY HOLES ALONG A CENTERLINE ALIGN WITHIN 6° OF THE SPADE AS SHOWN.

PORCELAIN NOTES:

1. WET PROCESS ELECTRICAL PORCELAIN.
2. GRAY GLAZE MUNSELL 5BG 7.0/0.4
3. TOLERANCE ±3% WITH NOTHING LESS THAN ±.03", UNLESS OTHERWISE NOTED ON DRAWING.

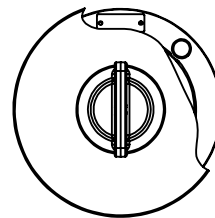

SPADE ORIENTATION VIEW

SPECIFICATIONS:

1. VOLTAGE RATING 46kV CLASS
2. BASIC IMPULSE LEVEL 250kV BIL
3. NOMINAL CURRENT RATING 417 AMPS
4. CREEP DISTANCE (MINIMUM) 42.50 [1079.50]
5. STRIKE DISTANCE (MINIMUM) 18.75 [476.25]
6. APPROXIMATE WEIGHT 63.65 LBS

TOLERANCES (EXCEPT AS NOTED)

DECIMAL	.X" = ±.1" .XX" = ±.06" .XXX" = ±.03"
ANGULAR	+/- 1 Degrees



H - J ENTERPRISES, INC.
 3010 HIGH RIDGE BLVD. HIGH RIDGE, MO. 63049 USA
 PHONE 1-636-677-3421 FAX 1-636-376-1915

46 kV CLASS POWER BUSHING

MATERIAL (SEE DRAWING)

CHK'D CJT APP'D 05/21/15 DRAWING NO. AS1774-005
 SCALE N.T.S.

PROPRIETARY AND CONFIDENTIAL
 THE INFORMATION CONTAINED IN THIS DRAWING IS THE SOLE PROPERTY OF H-J ENTERPRISES, INC. ANY REPRODUCTION IN PART OR AS A WHOLE WITHOUT THE WRITTEN PERMISSION OF H-J ENTERPRISES, INC. IS PROHIBITED.

DRAWN BY CLS

DATE 1/30/2014